

To: All Distributors and Dealers
 From: ECHO® Product Service
 Date: August 1, 1986 Revised November 30, 2020
 Subject: ECHO Model CS-500VL

Route to: Initials
 Service
 Sales
 Parts
 Office

Affected ECHO Model	Affected Serial Number Range
CS-500VL	0000001-0023000

Problem

ECHO has been advised of injuries sustained by operators of the CS-500VL chainsaw due to the fracture of the flywheel at high speeds.

Laboratory analysis and field investigations have indicated that the failures are caused by the use of incorrect tools and techniques when removing the flywheel.

ECHO has voluntarily instituted a recall program of the CS-500VL and will replace it free of charge with a new comparably sized saw with a 20 inch bar and chain.

The affected chainsaws flywheel can be identified by the thickness of the flywheel fins to the bottom of the flywheel base.

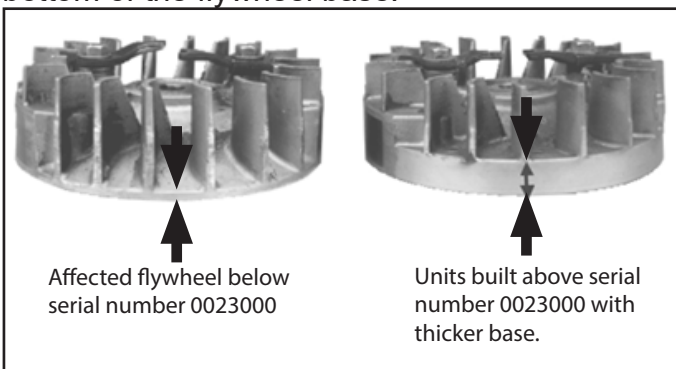
**Solution**

The saw that is affected in this recall is the CS-500VL within the serial number range 0000000 – 0023000. The CS-500EVL is NOT AFFECTED by this recall. Owners of the CS-500VL saw within the serial number range listed should return their saw to an authorized ECHO Service Dealer. The dealer will send the affected saw to ECHO Incorporated and file a warranty claim on the business portal. A free re-

placement chainsaw will be shipped back to the dealer or customer upon receipt of the recalled chainsaw.

Claim Processing and Shipping Instructions

The recall procedure on the following bulletin has changed over the years. Please use the following steps to submit a recall request.

1. Verify that the chainsaws serial number is below 23000 and that is a CS-500VL, not a CS-500EVL.
2. In the return authorization box on the electronic claim form enter CP686.
3. Enter the model number on the claim as a CS-5000 and enter the serial number from the CS-500VL that is subject to the recall. The system will not accept the CS-500VL model number.
4. Use the date the claim is entered as the purchase date, failure date and repair date.
5. Enter the customer name and address information on the claim.
6. Under Cause/Description of failure write CS-500VL Recall.
7. Under Work Performed Under Warranty write ECHO is shipping a comparably sized saw (with a 20 inch bar and chain) per recall CP686. Note on the warranty claim in the “Work Performed” section if you want the saw shipped to you for set-up. If not noted, the replacement saw will be shipped directly to the customer.
8. Under the Return Parts Shipping Amount section include your shipping cost to ECHO. This claim will be processed for payment upon receipt of the unit by ECHO.

9. Before boxing up the saw (power head only) back to ECHO make sure to drain all gas and oil from the saw. Do not return the old bar and chain but make sure to include a copy of the warranty claim in the box, and ship to.

ECHO Incorporated
400 Oakwood Rd.
Lake Zurich, IL 60047
Attention ECHO's Product Service Department – CP686

10. Once received ECHO will send the replacement to the customer (or dealer) and release the warranty claim for shipping credit to be processed as a normal warranty. Replacement saw processing time is 2 to 4 weeks.